



alples

MAGNET

SPALNICA

SPAVAĆA SOBA
BEDROOM



DOBRO
POČUTJE
VKLJUČENO!

INSPIRACIJA
IZ PRIRODE ZA
SVJEŽE JUTRO.
DOBRO OSJEĆANJE
UKLJUČENO!

INSPIRATION FROM
NATURE FOR FRESH
MORNINGS.
WELLBEING
INCLUDED!

POHIŠTVO ZA ZDRAVE NOĆI

Spalnica je v vsakem domu eden najbolj zasebnih prostorov, v katerem preživimo veliko ur. Res največ od teh ur prespimo, a je vseeno pomembno, da je spalnica ukrojena po naših merah, v nam ljubih barvah in premišljenih oblikah. Še bolj pa je pomembno, da materiali, iz katerih je narejena, omogočajo zdravo spanje. Surovine, ki jih uporabljamo, so rezultat trajnostno naravnane krožnega gospodarjenja, pri izdelavi se uporablja recikliran les in lepila z minimalno vsebnostjo topil. Tako ustvarjen bivalni prostor nas pospremi v mirno noč in zbudi v svež nov dan.

NAMJEŠTAJ ZA ZDRAVE NOĆI

Spavaća soba je jedan od najintimnijih prostora u svakom domu u kojem provodimo mnogo sati. Doduše, većinu ovih sati provedemo spavajući, no ipak je važno da spavaća soba bude prilagođena našim mjerama, u našim omiljenim bojama i promišljenim oblicima. Još je pak važnije da materijali od kojih je napravljena omogućavaju zdrav san. Sirovine koje upotrebljavamo rezultat su održivog kružnog gospodarstva. U izradi se upotrebljava reciklirano drvo i ljepila s minimalnim sadržajem otapala. Tako osmišljen životni prostor prati nas u mirnu noć i budi u svež dan.

FURNITURE FOR HEALTHY NIGHTS

In every home, the bedroom is one of the most private spaces, in which we spend many hours. In reality, we sleep during most of those hours, but it is still important that the bedroom is custom-made for us, in the colours we love and in well-conceived designs. What is even more important is that the materials from which it is made enable healthy sleep. The raw materials we use are the result of sustainability-oriented circular management, and recycled wood and adhesives with minimal solvent content are used in the manufacturing process. A living space that is thus created takes us into a peaceful night and awakens us to a fresh new day.





SPALNICA #01



MAGNET

Spavaća soba / Bedroom

KOT SPANJE
NA OBLAKU

VZGLAVJEM ZRAČNA
POSTELJA Z
MEHKIM

AN AIRY BED WITH A
SOFT PILLOW - LIKE
SLEEPING ON A CLOUD

PROZRAČNI KREKET S
MEKANIM UZGLAVLJEM
- KAO SPAVANJE NA
OBLAKU

Nič ni bolj vabljivega kot mehko postlana postelja, urejena v skladu z našim načinom bivanja. Dopolnjujejo jo v prvi vrsti uporabni elementi, ki pa s svojo lepoto in naravnim videzom prinašajo v dom vtis zračnosti narave.

Nema ništa primamnije od meko namještenog kreveta, uređenog prema našem načinu življenja. Nadopunjuju ga prvenstveno korisni elementi koji svojom ljepotom i prirodnim izgledom u dom unose dojam prozračnosti prirode.

Nothing is more tempting than a soft bed arranged according to our way of life. It is complemented primarily by useful elements that, with their beauty and natural appearance, bring an impression of the airiness of nature into the home.





SPALNICA #02



MAGNET

Spavaća soba / Bedroom





DODATNI
PROSTOR ZA
SHRANJEVANJE
NI NIKOLI
ODVEČ

POD VZMETNICO POSTELJA S
SHRAMBO



KREKET S PROSTOROM ZA
POHRANU ISPOD MADRACA:
DODATNI PROSTOR ZA POHRANU
NIKADA NIJE NA ODMET

BED WITH UNDER-MATTESS
STORAGE: EXTRA STORAGE SPACE
IS NEVER SUPERFLUOUS

**Med črno in belo je
cel svet odtenkov.
Nekateri se nam
zgodijo, za druge
se odločimo sami.
Izbrali smo ljudi,
s katerimi živimo.
Izberimo še odtenke
spalnice, ki so
nam najbolj všeč,
elemente, ki jih
najbolj potrebujemo
in imejmo radi ljudi,
ki smo jih izbrali.**

Između crne i bijele boje
postoji cijeli svijet nijansi.
Neke nam se dogode, a za
druge se sami odlučimo.
Odabrali smo ljude s kojima
živimo. Odaberimo i nijanse
spavaće sobe koje nam se
najviše sviđaju, elemente
koji su nam najpotrebniji
i volimo ljude koje smo
odabrali.

There is a whole world
of hues between black
and white. Some happen
to us, while we ourselves
opt for others. We choose
the people we live with.
Let's choose the bedroom
hues that we like best, the
elements that we need
the most and let's love the
people we have chosen.

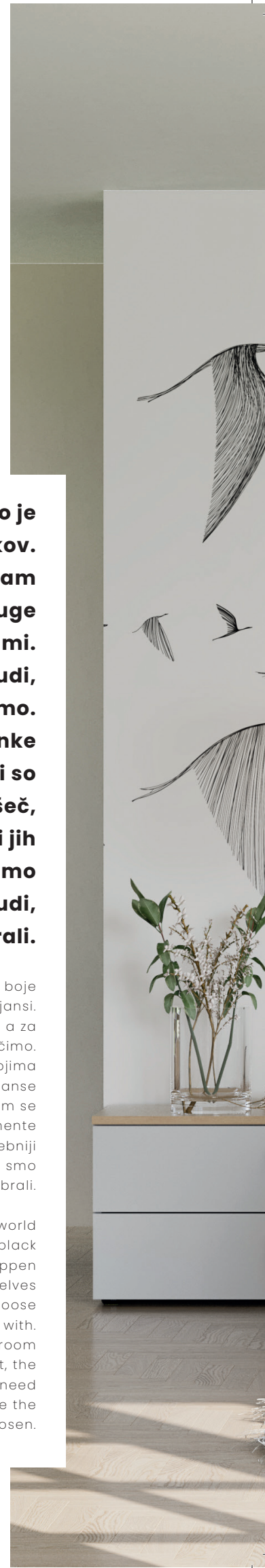

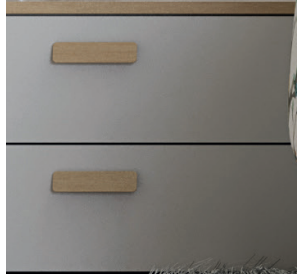

SPALNICA #03



MAGNET

Spavaća soba / Bedroom







NIŠA ZA VIŠE
 PRAKTIČNOSTI - U ZRAKU I
 NA DOHVAT RUKE
 A NICHE FOR MORE
 HANDINESS - IN THE AIR
 AND WITHIN ARM'S REACH

NIŠA ZA VIŠE
 PRAKTIČNOSTI - U ZRAKU I
 NA DOHVAT RUKE

A NICHE FOR MORE
 HANDINESS - IN THE AIR
 AND WITHIN ARM'S REACH









SPALNICA #04



MAGNET

Spavaća soba / Bedroom



TOALETNI KUTAK PRETVARA
SE U RADNI PROSTOR:
ELEGANCIJA I KORISNOST U
ISTO VRIJEME

A DRESSING TABLE CORNER
TRANSFORMED INTO A
WORKSPACE:
ELEGANCE AND USABILITY
AT THE SAME TIME

TOALETNI KOTIČEK SE PRETVARAJE
V DELOVNI PROSTOR
ELEGANCA IN
UPORABNOST
OBENEM



**Dodatni delovni prostor
pride prej ali slej prav.
Miren prostor nam
omogoči, da se lažje
osredotočimo na delo in ga
bolj učinkovito opravimo.
Potem pa je prostor spet
samo spalnica, elegantna
in navdihujoča.**

Dodatni radni prostor dobro
dode prije ili kasnije. Miren
prostor omogućava nam da
se lakše usredotočimo na
posao i da ga učinkovitije
odradimo. Nakon toga
je prostor opet samo
spavaća soba, elegantna i
inspirativna.

Extra workspace comes in
handy sooner or later. A
quiet space enables us to
focus more easily on our
work and to do it more
effectively. Then the room
is just a bedroom again,
elegant and inspiring.





POHIŠTVO, KI PREDVIDEVA, ŽIVLJENJSKA PRESENEČENJA

NAMJEŠTAJ KOJI PREDVIĐA ŽIVOTNA IZNENAĐENJA
FURNITURE THAT FORESEES LIFE'S SURPRISES

Življenja ni mogoče popolnoma načrtovati, včasih imamo občutek, da se z nami igra ali celo iz nas norčuje. Tudi opremljanje spalnice je včasih težka naloga, potem pa se še spremenijo naše potrebe. Več kot dragoceno je zato zavedanje, da z nakupom spalnice ne bomo naredili nepopravljive napake.

Naše izdelke snujemo z mislijo na spreminjajoče se potrebe uporabnikov, zato so programi širši, imajo veliko različnih elementov in več barv, ročajev, njihova kvaliteta pa omogoča večkratno prestavljanje. Pri naših uporabnikih niso nič redkega dokupi ali spremembe v postavitvah. Ker nam je mar zadovoljstvo naših uporabnikov, nam manjši dokupi ali servis niso odveč.

Život nije moguće u potpunosti isplanirati, ponekad imamo osjećaj da se s nama igra ili nam se čak izruguje.

I opremanje spavaće sobe je ponekad težak zadatak, a naknadno se naše potrebe još i promijene. Stoga je više nego dragocjeno biti svjestan da kupnjom spavaće sobe nećemo napraviti nepopravljivu grešku.

Svoje proizvode osmišljamo imajući na umu promjenjive potrebe korisnika, pa su programi širi, imaju mnogo različitih elemenata i više boja, ručki, a njihova kvaliteta omogućuje višestruko premještanje. Dodatne kupnje ili promjene izgleda nisu neuobičajene kod naših korisnika. Budući da nam je stalo do zadovoljstva naših korisnika, manji dokupi ili servisi nisu nam gnjavaža.

Life cannot be completely planned; sometimes we have a feeling that it is playing with us or even making fun of us.

Even furnishing a bedroom is sometimes a difficult task, and then our needs change as well. Therefore, awareness that buying a bedroom will not be an irreversible mistake is more than valuable.

Our products are designed with changing user needs in mind, so the ranges are broader, they have many different elements and multiple colours, handles, and their quality allows for multiple shifting. Additional purchases or changes in the layout are not uncommon for our users. Because we care about the satisfaction of our users, small purchases or servicing are not a nuisance to us.

PROTECT YOU TECHNOLOGY

ZAŠTITA OD
ZRAČENJA CIJELU
NOĆ – ZA NESMETANU
REGENERACIJU
MOZGOVA.

ALL-NIGHT RADIATION
PROTECTION – FOR
THE UNINTERRUPTED
REGENERATION OF
BRAINS



Spanje je nujno potrebno za nemoteno telesno in duševno delovanje. Med spanjem poteka regeneracija celotnega organizma, še posebej pa je pomembna regeneracija možganov. Sevanje mobilnih naprav na ta proces vpliva negativno, zato ga želimo čim bolj omejiti. Tkanina, ki jo vgrajujemo v določene elemente, 99-odstotno prepreči prehod sevanja. Elementi so zasnovani tako, da smo preko mobilne naprave še vedno dosegljivi, sevanje pa se zmanjša na najmanjšo možno mero.

Spavanje je prijetno potrebno za nesmetano tjelesno i duševno funkcioniranje. Tijekom spavanja događa se regeneracija cijelog organizma, a posebno je važna regeneracija mozga. Zračenje mobilnih telefona na taj proces utječe negativno, zato ga želimo što više ograničiti. Tkanina koju ugrađujemo u određene elemente 99 % sprječava prolaz zračenju. Elementi su osmišljeni tako da smo putem mobilnog uređaja još uvijek dostupni, a zračenje se smanjuje na najmanju moguću mjeru.

Sleep is essential for smooth physical and mental functioning. During sleep, the regeneration of the entire organism takes place, with the regeneration of the brain being especially important. The radiation from mobile devices negatively impacts this process, so we want to limit it as much as possible. The fabric, which is built into certain elements, provides 99% protection against the passage of radiation. The elements are designed so that we can still be reached via a mobile device, while radiation is reduced to a minimum.



PROTECT YOU
TECHNOLOGY

Senčeni deli imajo možnost vseh barv.
 Zasjenjeni dijelovi imajo mogućnost svih boja.
 Shaded parts are available in all of the colours.



OSNOVNI ELEMENTI / OSNOVNI ELEMENTI / BASIC ELEMENTS

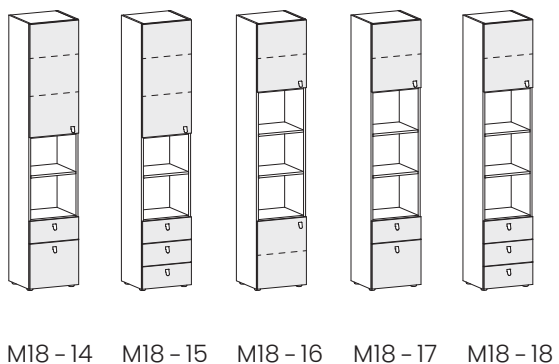
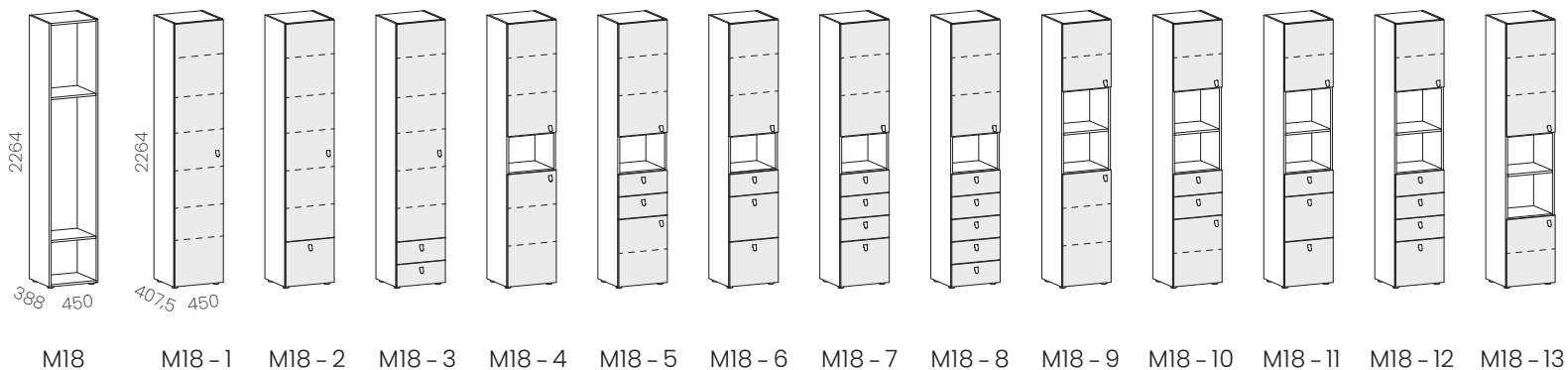
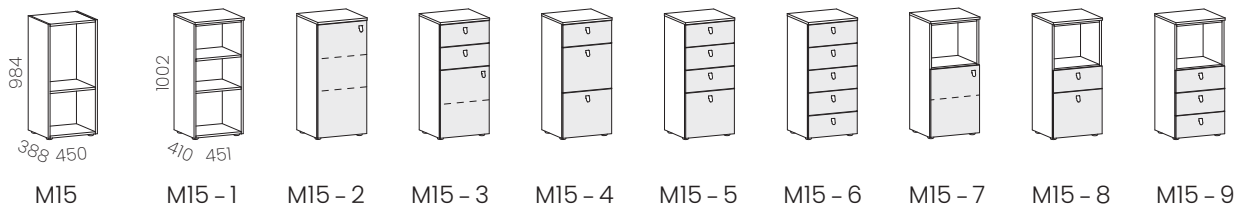
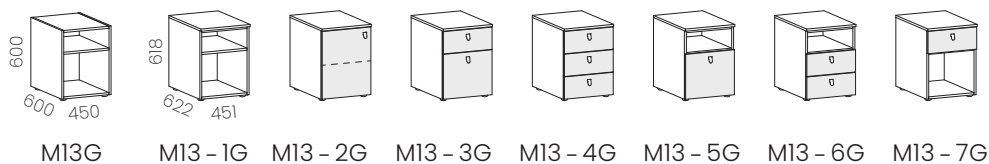
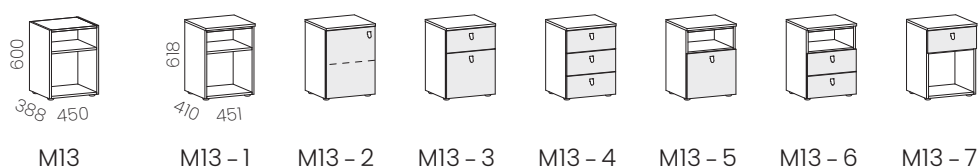
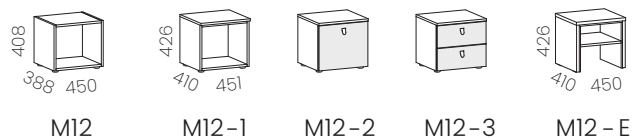

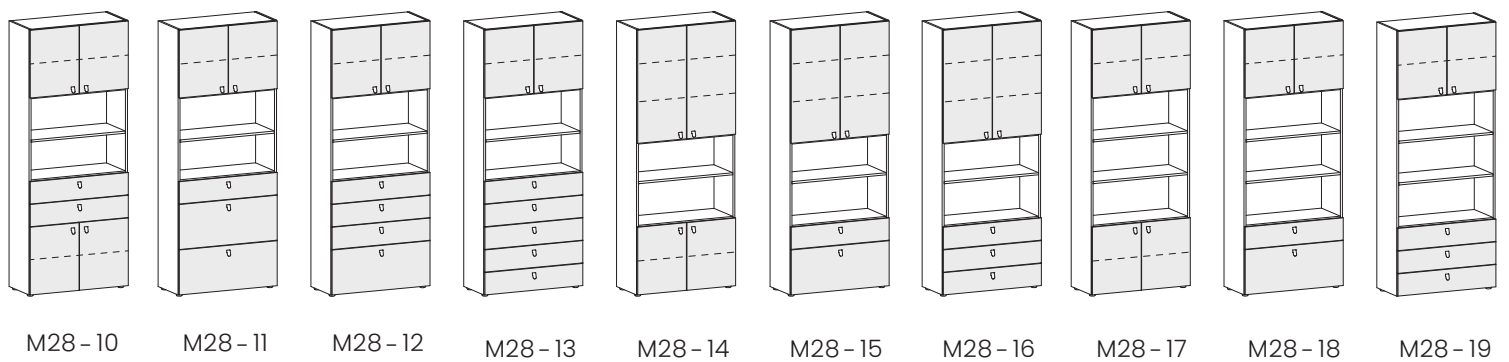
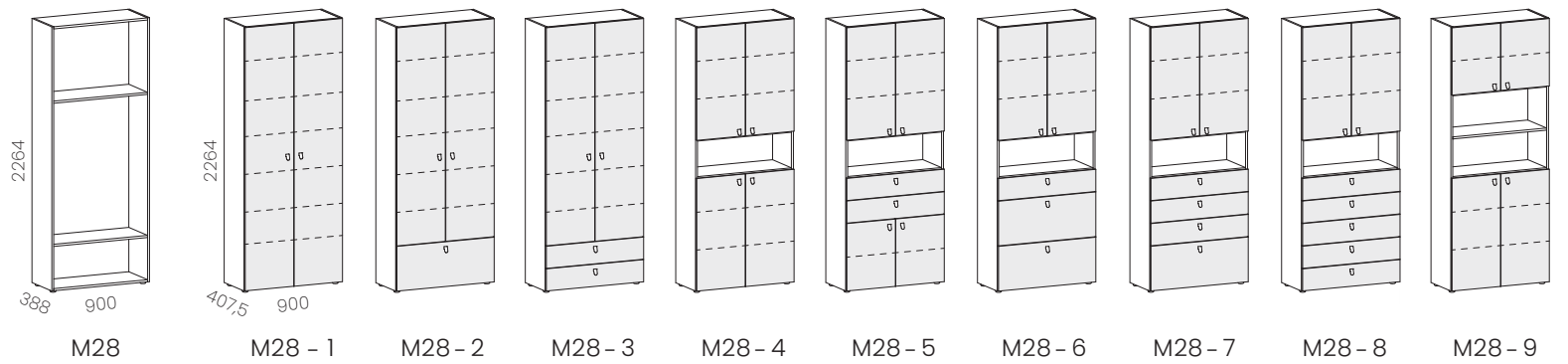
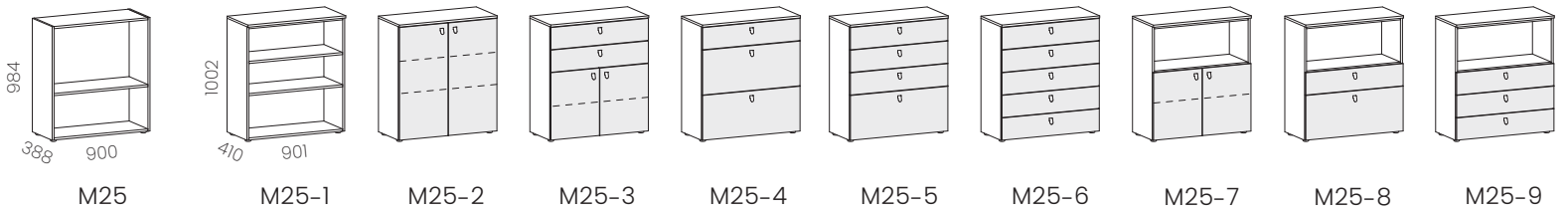
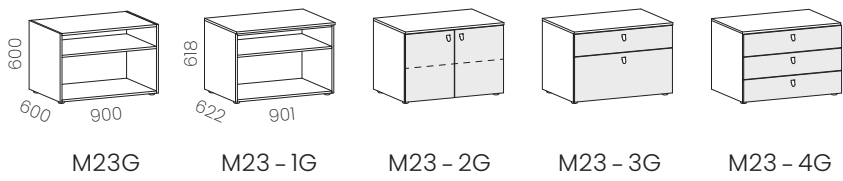
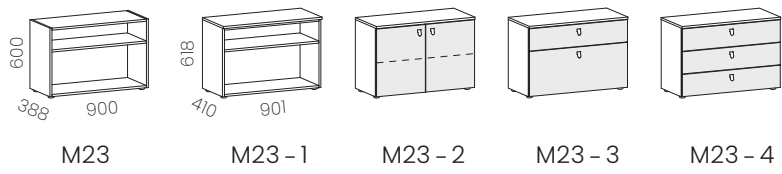
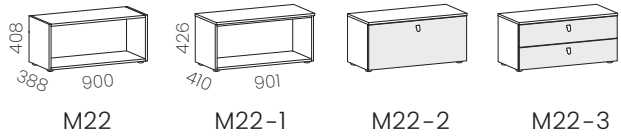

GARDEROBNI ELEMENTI / GARDEROBNI ELEMENTI / WARDROBES

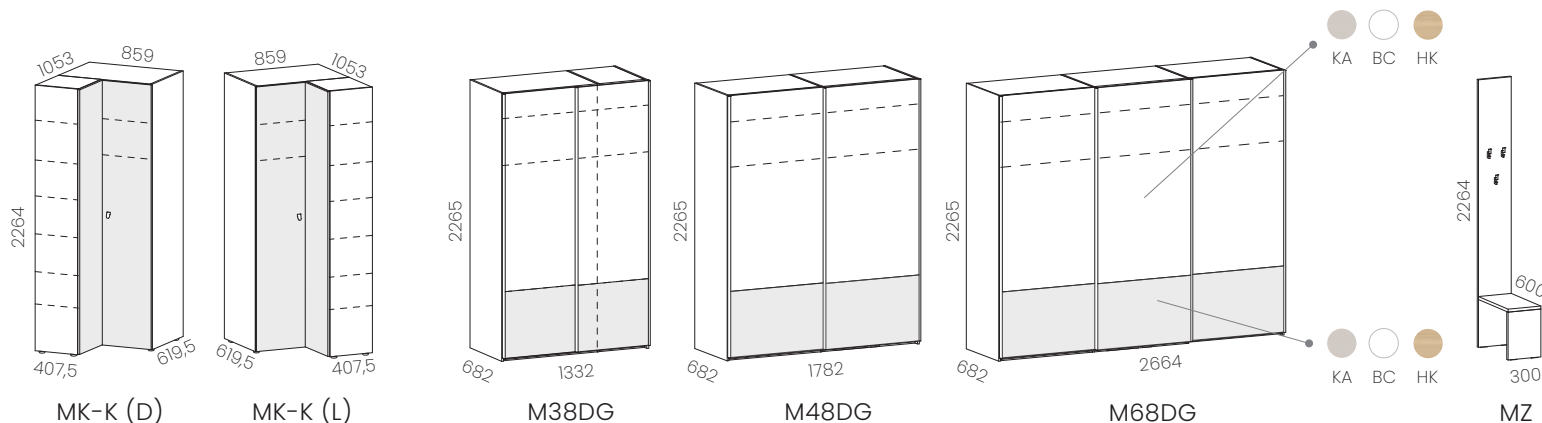
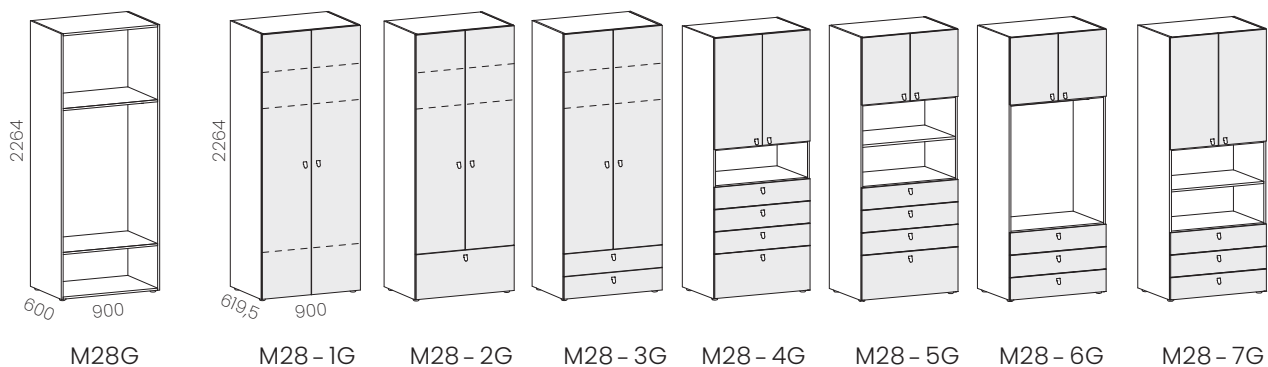
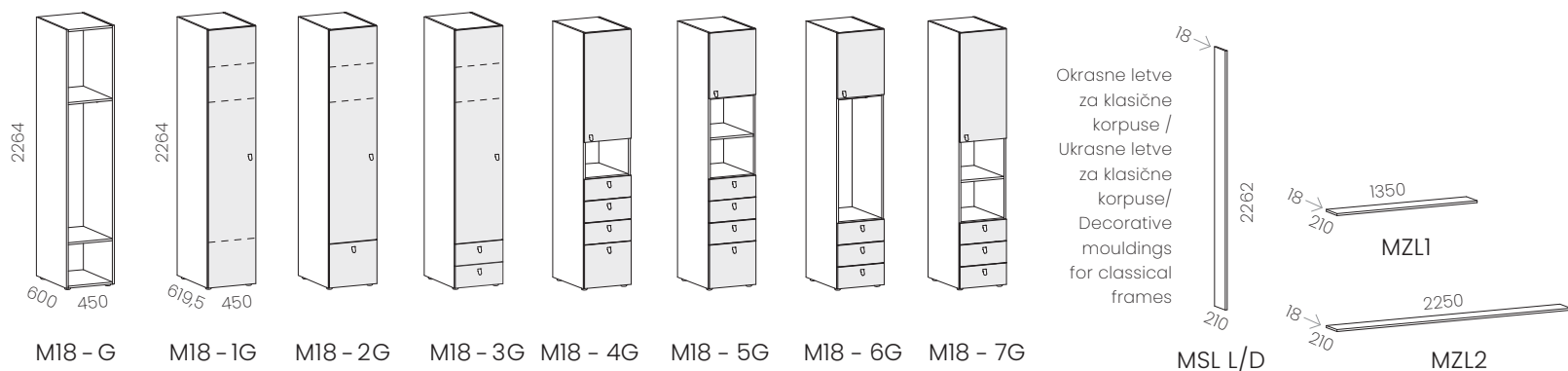

ni možna uporaba dodatkov garderobnih omar
/ nije moguće koristiti dodatke garderobnih ormara
/ it is not possible to use wardrobe interior elements

DODATKI GARDEROBNIH OMAR / DODACI GARDEROBNIH ORMARA / WARDROBE INTERIOR ELEMENTS

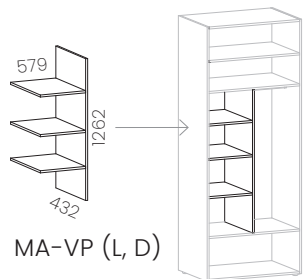

Element se vstavi med 2 horizontali / Element je umetnut izmedu 2 horizontale / The element is inserted between 2 horizontals

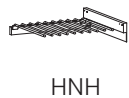
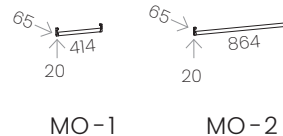
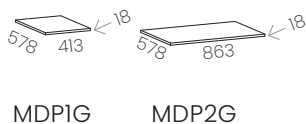

blažilec za / ublaživač za
/ blu motion for M38-DG & M48-DG

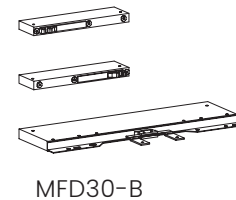

Blažilec za / ublaživač za
/ blu motion for M68DG

DODATNI ELEMENTI / DODATNI ELEMENTI / SUPPLEMENTAL ELEMENTS

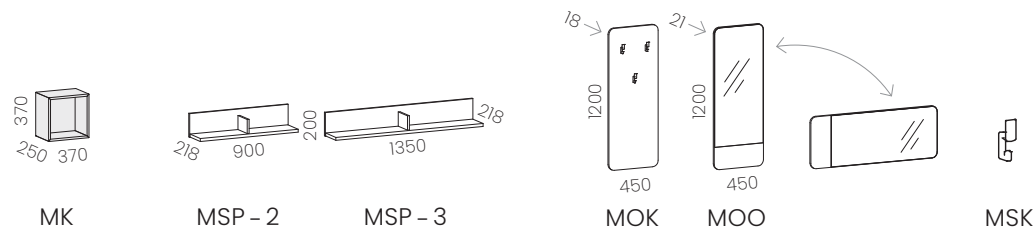

SVETILA / SVJETILJKE / LIGHTS

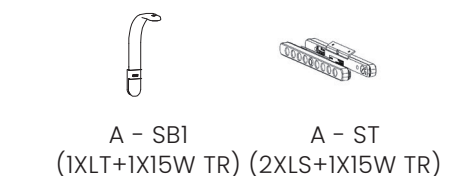

LT - svetilo s stikalom na dotik • svjetiljka sa prekidačem na dodir • light with touch switch

LS - svetilo s senzorjem gibanja • svjetiljka sa senzorom pokreta • light with motion sensor

TR - vtič s transformatorjem in kablom • utikač sa transformatorom i kabelom • plug with transformer and cable

VIŠEČI ELEMENTI / VIŠEĆI ELEMENTI / WALL MOUNTED ELEMENTS

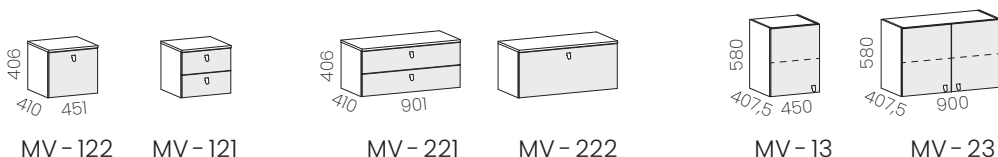

FRONTE / VRATA I LADICE / DOORS AND DRAWERS

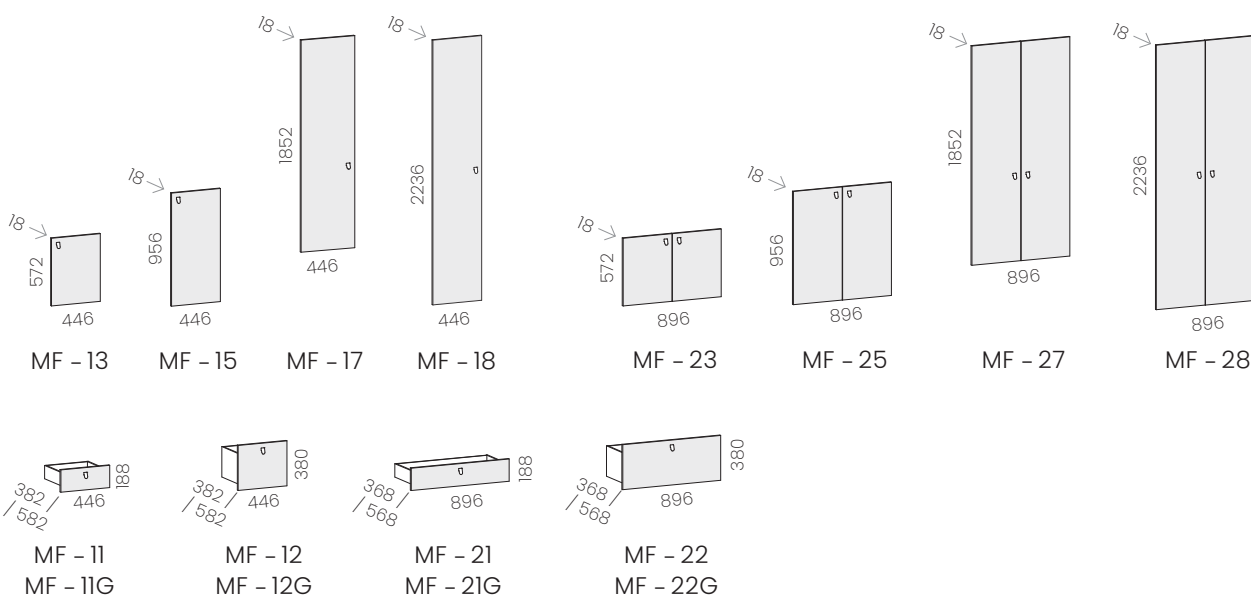

POKRIVNE PLOŠČE / POKRIVNE PLOČE / TOP PANELS

DODATNE POLICE / DODATNE POLICE / ADDITIONAL SHELVES

VMESNE POLICE / VEZNA POLICE / BRIDGE SHELVES

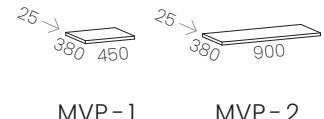
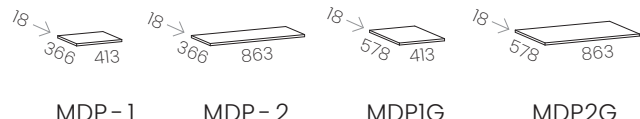
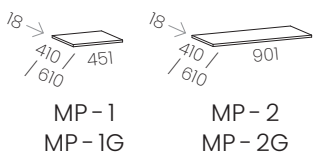

MP-1
MP-1G

MP-2
MP-2G

MDP-1

MDP-2

MDP1G

MDP2G

MVP-1

MVP-2

POSTELJE / KREVETI / BEDS

Oblazinjena vzglavna končnica v treh barvah tkanine / Tapecirano uzglavlje u tri boja tkanine / Upholstered headboard in three colours of fabrics

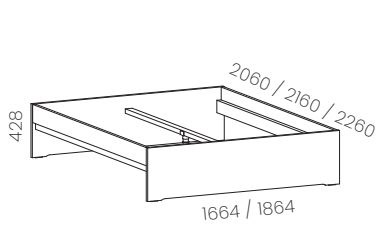

ML 160N / 200, 210, 220
ML 180N / 200, 210, 220

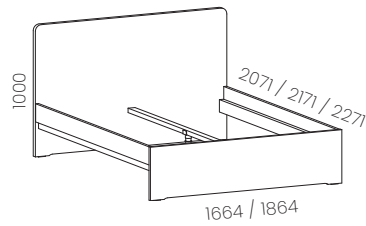

ML 160V / 200, 210, 220
ML 180V / 200, 210, 220

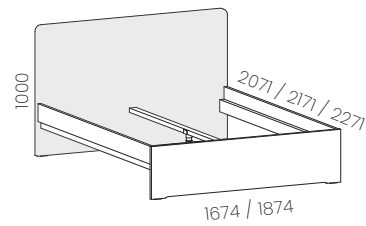

ML 160T / 200, 210, 220
ML 180T / 200, 210, 220

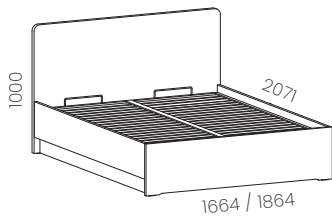

ML 160D / 200
ML 180D / 200

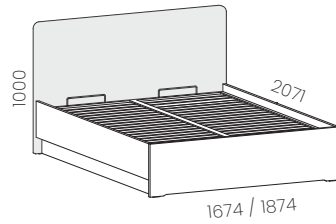

ML 160DT / 200
ML 180DT / 200

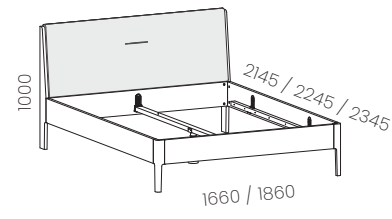

ML 160KT / 200, 210, 220
ML 180KT / 200, 210, 220



Nastavljivost dna po višini
Mijenjanje visine dna kreveta
Bottom changing height

Samo v lesnem dekorju!
Samo u drvenom dekoru!
Only in wood decor!

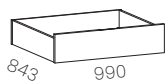

ML - P

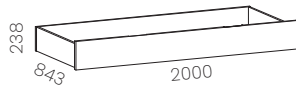

ML - D

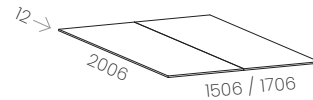

MTZ 160 / 200
MTZ 180 / 200

zaščitno dno pri dvizni postelji
zaštitno dno na krevetu za podizanje
protective bottom for lifting bed

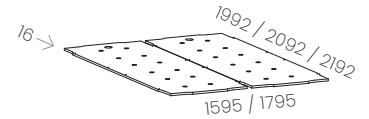

BLED 160 / 200, 210, 220
BLED 180 / 200, 210, 220

PISALNE MIZE / PISAČI STOLOVI / WRITING DESKS

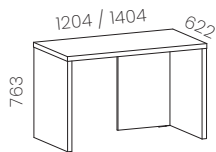

MPMIO (L, D)
MPM2O (L, D)

na sliki je L izvedba
na slici je L izvedba
the picture shows L version

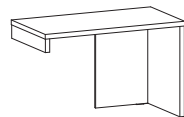

MPMIN (L, D)
MPM2N (L, D)

na sliki je L izvedba
na slici je L izvedba
the picture shows L version

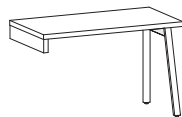

MPMINK (L, D)
MPM2NK (L, D)

na sliki je L izvedba
na slici je L izvedba
the picture shows L version

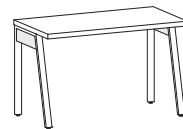

MPMIK
MPM2K

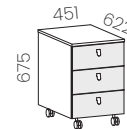

MP

SESTAVNI DELI PISALNIH MIZ PO MERI / KOMPONENTE PISAČIH STOLOVA PO MJERI / COMPONENTS FOR CUSTOM MADE WRITING DESK

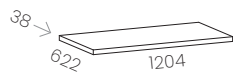

MPPL 1

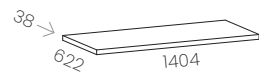

MPPL 2



MPPL



MN1

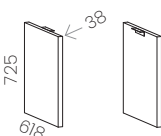

MN2(L) MN2(D)

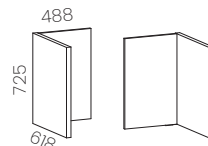

MN3(L) MN3(D)

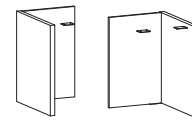

MN3K(L) MN3K(D)

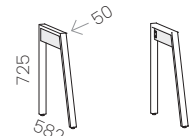

MNK(L) MNK(D)

BARVE *dekori / decors*

MAGNET

MOŽNE BARVNE KOMBINACIJE OSNOVNIH ELEMENTOV
 MOGUĆE KOMBINACIJE BOJA OSNOVNIH ELEMENTA
 AVAILABLE COLOUR COMBINATIONS OF BASIC ELEMENTS

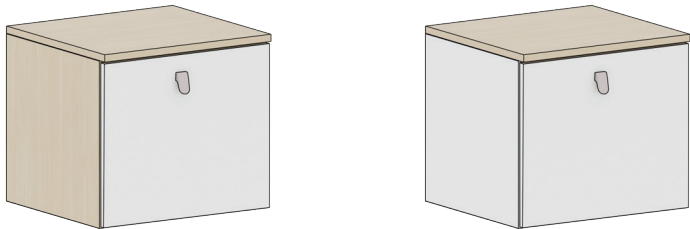

Primer:
 Primjer:
 Example:

HK/HK/BC

BC/HK/BC

Barve korpusa / Barve pokrivne plošče / Barve front
 Boje korpusa / Boje pokrivne ploče / Boje fronta
 Frame colours / Top panel colours / Colours of doors and drawers

Barve korpusa / Boje korpusa / Frame colours



Barve pokrivne plošče / Boje pokrivne ploče / Top panel colours

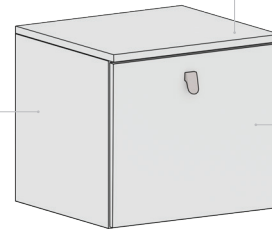

Barve front / Boje fronta /
 Colours of doors and drawers



V katalogu so fronte senčene s sivo.
 U katalogu su fronte zasjenjene sivom bojom.
 In the catalogue, front panels are shaded with gray.

BARVE FRONT / BOJE FRONTA / COLOURS OF DOORS AND DRAWERS

V katalogu so fronte senčene s sivo.
 U katalogu su fronte zasjenjene sivom bojom.
 In the catalogue, front panels are shaded with gray.



hrast / hrast / oak



kašmir siva / kašmir siva / cashmere grey

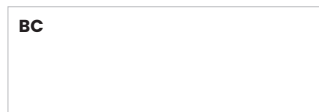

bela iveral / bijela / white

BARVE KORPUSA / BOJE KORPUSA / FRAME COLOURS

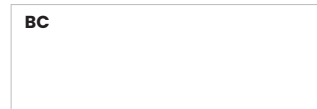

bela iveral / bijela / white



hrast / hrast / oak

TKANINE / TKANINE / FABRICS

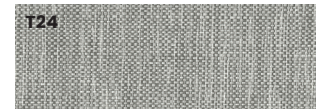

sahara / sahara



peščena / pješčana / sand

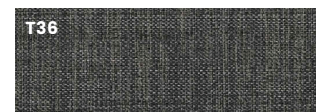

tamno siva / dark grey

ROČAJI / RUČKE / HANDLES

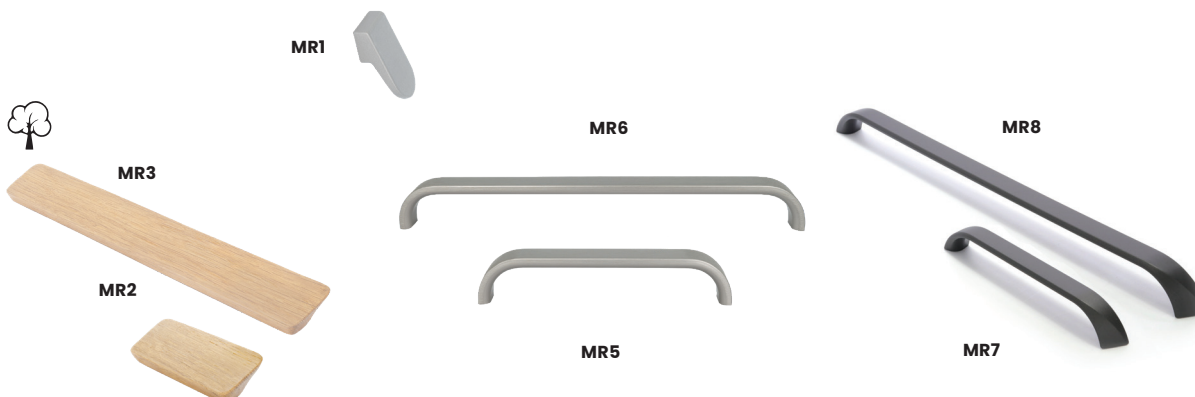

* Masivni les, ki je del spalnice, lahko barvno odstopa od melaminsko oplemenitene plošče.
 * Masivno drvo koje je dio spavaće sobe bojom može odstupati od ploče oplemenjene melaminom.
 * The solid wood that is a part of the bedroom may deviate in colour from the melamine-treated board.

Dekoratívni elementi, uporabljeni pri vizualizaciji, niso del prodajnega programa Magnet. Pridružujemo si pravico do tehničnih sprememb. **Oblikovanje pohištva:** Design team Alpes, Dana Poljanec, udia. **Tekst:** Marjana Rejc, udia. **Tisk:** Sinet d.o.o., 2022 **Oblikovanje:** www.leparec.si, **Vizualizacije:** www.arhivis.si

Dekoratívni elementi koji su upotrijebljeni kod vizualizacija nisu dio prodajnog asortimana programa Magnet. Pridržavamo pravo tehničkih promjena. **Dizajn namještaja:** Design team Alpes, Dana Poljanec, arh., **Tekst:** Marjana Rejc, arh. **Tisk:** Sinet d.o.o., 2022 **Dizajn:** www.leparec.si, **Vizualizacije:** www.arhivis.si

Decorative elements used in renderings are not part of the Magnet sales programme. Alpes reserves the right to change items. **Furniture design:** Design team Alpes, Dana Poljanec, arch. **Press:** Sinet d.o.o., 2022 **Text:** Marjana Rejc, arch. **Ad&renderings:** www.arhivis.si, www.leparec.si

Barve v katalogu lahko odstopajo od originalne barve izdelkov. / Boje u katalogu mogu biti različite od stvarne boje proizvoda. / The colours in the catalogue may deviate from the original colour of the products.

ALPES D.D. 4228 ŽELEZNIKI, SLOVENIA, EUROPE / ALPES.SI / ALPES@ALPES.SI / 003864 51 18 100

